



UNIVERSAL TRANSMISSION JACKS CARS AND VANS



Reversible transmission adaptor with saddle and rubber pad.

Ideal for handling and supporting exhaust systems, fuel tanks, etc.

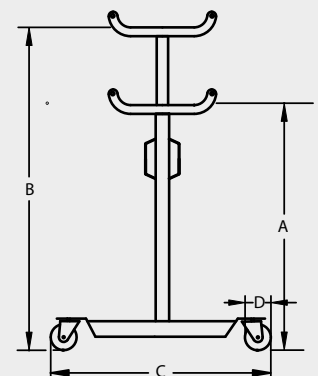
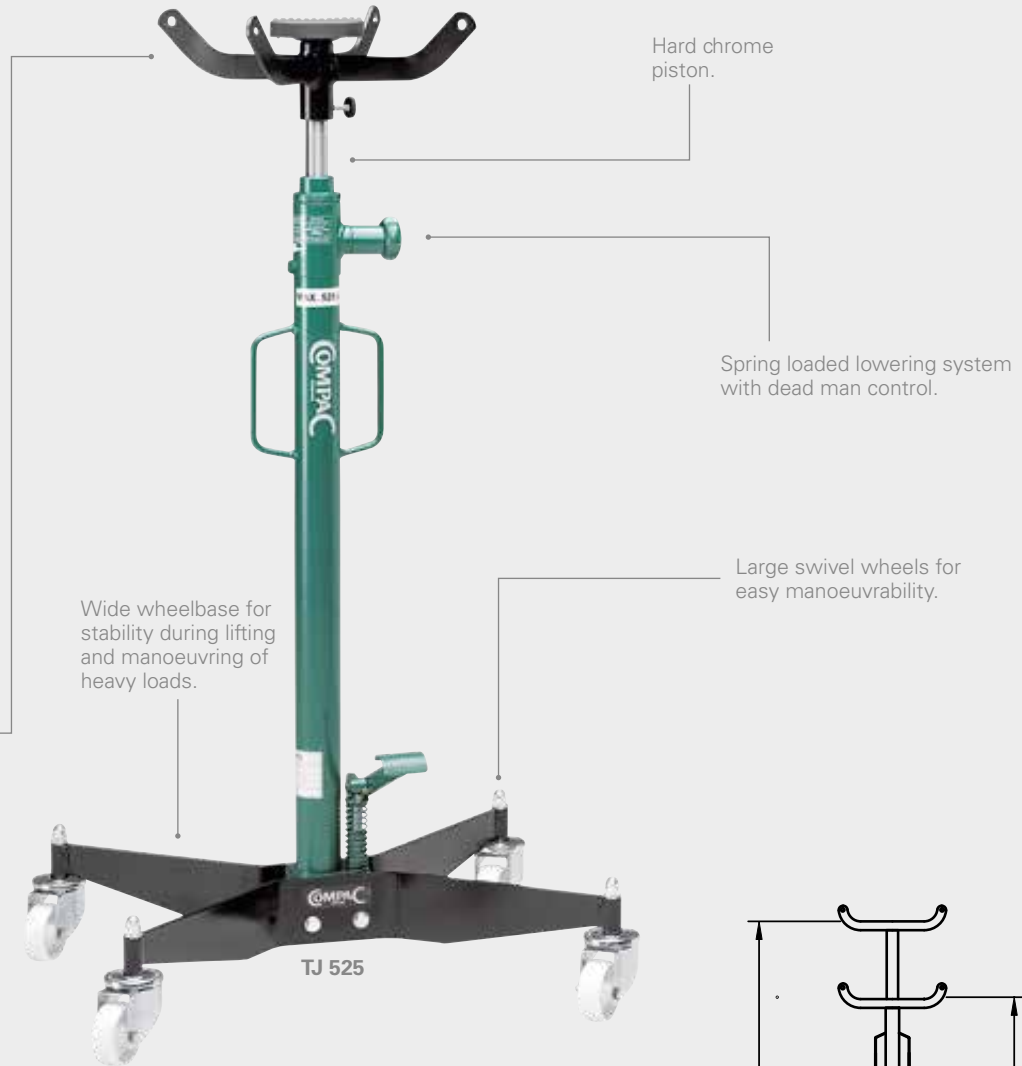

Model	Max (kg)	A (mm)	B (mm)	C (mm)	D (mm)	Kg
TJ 300	300	1095	1930	465 x 565	60	24
TJ 325	325	1170	2020	595 x 535	80	30
TJ 525	525	1170	2020	595 x 535	80	32
TJ 1000	1000	1170	2000	595 x 535	100	38